



2501 Ludelle Street
Fort Worth, Texas 76105
817-244-6212 Phone • 817-244-4024 Fax
888-350-6588 Sales • 800-423-9696 Tech
E-mail: painless@painlessperformance.com
Web: www.painlessperformance.com

50102

UNIVERSAL FUEL PUMP RELAY INSTALLATION INSTRUCTIONS

LOCATE THE RELAY ASSEMBLY CLOSE TO THE FUEL PUMP AND MOUNT WITH THE SCREW INCLUDED MAKING SURE TO ATTACH THE BLACK WIRE WITH THE RING TERMINAL TO CHASSIS GROUND AT THE SAME TIME.

2. MOUNT THE CIRCUIT BREAKER CLOSE TO THE POWER SOURCE.
3. ATTACH THE 12 GAUGE (LARGER) YELLOW/WHITE WIRE FROM THE RELAY TO THE FUEL PUMP.
4. ATTACH THE 18 GAUGE (SMALLER) YELLOW/WHITE WIRE TO A SWITCHED 12 VOLT SOURCE OR FUEL PUMP SWITCH, USING THE RED RING TERMINAL IF NECESSARY.
5. ATTACH THE RED 12 GAUGE WIRE TO THE CIRCUIT BREAKER AFTER CUTTING TO LENGTH, USING A YELLOW RING TERMINAL.
6. ATTACH THE REMAINING LENGTH OF RED WIRE BETWEEN THE BATTERY SOURCE AND THE UNUSED POST ON THE CIRCUIT BREAKER USING THE YELLOW TERMINAL PROVIDED.

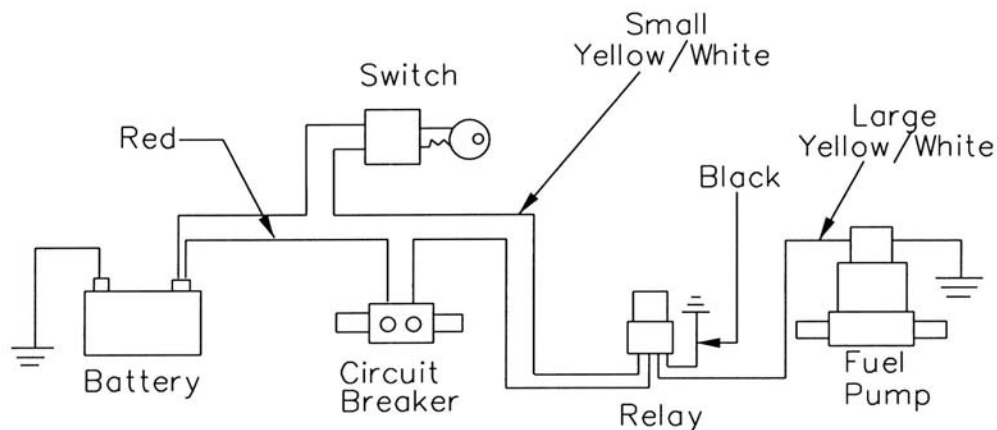

Painless Performance Limited Warranty and Return Policy

Chassis harnesses and fuel injection harnesses are covered under a lifetime warranty. All other products manufactured and/or sold by Painless Performance are warranted to the original purchaser to be free from defects in material and workmanship under normal use. Painless Performance will repair or replace defective products without charge during the first 12 months from the purchase date. No products will be considered for warranty without a copy of the purchase receipt showing the sellers name, address and date of purchase. You must return the product to the dealer you purchased it from to initiate warranty procedures.